

TECHNICAL MANUAL
Of
VIA VX800
Based
Mini-ITX M/B For C7/Eden/Nano
Processor

NO.G03-NF76-F

Rev2.0

Release date: Feb., 2009

Trademark:

* Specifications and Information contained in this documentation are furnished for information use only, and are subject to change at any time without notice, and should not be construed as a commitment by manufacturer.

Environmental Protection Announcement

Do not dispose this electronic device into the trash while discarding. To minimize pollution and ensure environment protection of mother earth, please recycle.



TABLE OF CONTENT

USER'S NOTICE	iii
MANUAL REVISION INFORMATION	iii
ITEM CHECKLIST	iii
CHAPTER 1 INTRODUCTION OF VIA CHIPSET MOTHERBOARD	
1-1 FEATURE OF MOTHERBOARD	1
1-2 SPECIFICATION	2
1-3 LAYOUT DIAGRAM & JUMPER SETTING	3
CHAPTER 2 HARDWARE INSTALLATION	
2-1 JUMPER SETTING	7
2-2 CONNECTORS AND HEADERS	11
2-2-1 CONNECTORS	11
2-2-2 HEADERS	12
CHAPTER 3	
3-1 ENTERING SETUP	21
3-2 GETTING HELP	21
3-3 THE MAIN MENU	21
3-4 ADVANCED BIOS FEATURES	24
3-4-1 CPU FEATURE	27
3-5 INTERGRATED PERIPHERALS	28
3-6 PC HEALTH STATUS	29
3-7 ADVANCED CHIPSET FEATURES	30
3-8 POWER MANAGEMENT SETTING	31
3-9 PnP/PCI CONFIGURATION	32
3-10 MISCELLANEOUS CONFIGURATION	33



Safety Environmental Instruction

- Avoid the dusty, humidity and temperature extremes. Do not place the product in any area where it may become wet.
- 0 to 60 centigrade is the suitable temperature. (The figure comes from the request of the main chipset)
- Generally speaking, dramatic changes in temperature may lead to contact malfunction and crackles due to constant thermal expansion and contraction from the welding spots' that connect components and PCB. Computer should go through an adaptive phase before it boots when it is moved from a cold environment to a warmer one to avoid condensation phenomenon. These water drops attached on PCB or the surface of the components can bring about phenomena as minor as computer instability resulted from corrosion and oxidation from components and PCB or as major as short circuit that can burn the components. Suggest starting the computer until the temperature goes up.
- The increasing temperature of the capacitor may decrease the life of computer. Using the close case may decrease the life of other device because the higher temperature in the inner of the case.
- Attention to the heat sink when you over-clocking. The higher temperature may decrease the life of the device and burned the capacitor.

USER'S NOTICE

COPYRIGHT OF THIS MANUAL BELONGS TO THE MANUFACTURER. NO PART OF THIS MANUAL, INCLUDING THE PRODUCTS AND SOFTWARE DESCRIBED IN IT MAY BE REPRODUCED, TRANSMITTED OR TRANSLATED INTO ANY LANGUAGE IN ANY FORM OR BY ANY MEANS WITHOUT WRITTEN PERMISSION OF THE MANUFACTURER.

THIS MANUAL CONTAINS ALL INFORMATION REQUIRED TO USE INTEL 945GM CHIPSET MOTHER-BOARD SERIES AND WE DO ASSURE THIS MANUAL MEETS USER'S REQUIREMENT BUT WILL CHANGE, CORRECT ANY TIME WITHOUT NOTICE. MANUFACTURER PROVIDES THIS MANUAL "AS IS" WITHOUT WARRANTY OF ANY KIND, AND WILL NOT BE LIABLE FOR ANY INDIRECT, SPECIAL, INCIDENTAL OR CONSEQUENTIAL DAMAGES (INCLUDING DAMAGES FOR LOSS OF PROFIT, LOSS OF BUSINESS, LOSS OF USE OF DATA, INTERRUPTION OF BUSINESS AND THE LIKE).

PRODUCTS AND CORPORATE NAMES APPEARING IN THIS MANUAL MAY OR MAY NOT BE REGISTERED TRADEMARKS OR COPYRIGHTS OF THEIR RESPECTIVE COMPANIES, AND THEY ARE USED ONLY FOR IDENTIFICATION OR EXPLANATION AND TO THE OWNER'S BENEFIT, WITHOUT INTENT TO INFRINGE.

Manual Revision Information

Reversion	Revision History	Date
2.0	Second Edition	February, 2009

Item Checklist

- Motherboard
- Cable(s)
- CD for motherboard utilities
- Motherboard User's Manual
- Back panel

Chapter 1

Introduction of the Motherboard

1-1 Feature of motherboard

- * VIA VX800 chipset.
- * Onboard C7/Eden/Nano CPU, with low power consumption never denies high performance.
- * Support FSB 800MHz.
- * Support DDRII 400/533/667 up to 2GB.
- * Onboard REALTEK RTL 8111C Gigabit Ethernet LAN.
- * Integrated VIA 1708B 6-channel HD audio CODEC
- * Support USB2.0 data transport demands.
- * Support RS232/422/485 and watchdog.

1-2 Specification

Spec	Description
Design	* Mini ITX form factor 6 layers PCB size: 17.0x17.0cm
Chipset	* VIA VX800 Chipset
Embedded CPU	* C7 /Eden/Nano CPU
Memory Socket	* 240-pin DDRII DIMM socket x1 * Support DDRII 400/533/667MHz system Modules DDR memory * Expandable to 2GB.
Expansion Slots	* 32-bit PCI slot x 1pcs
Integrate IDE	* One PCI IDE controller that supports PCI Bus Mastering, ATA PIO/DMA and the ULTRA DMA 133/100/66 functions that deliver the data transfer rate up to 100 MB/s.
LAN	* Integrated Realtek RTL8111C PCI-E LAN. * Support Fast Ethernet LAN function of providing 10Mb/100Mb/1000Mb Ethernet data transfer rate
Audio	* VIA 1708B 6 channel Audio Codec integrated * Audio driver and utility included
BIOS	* Award 8MB Flash ROM
Multi I/O	* PS/2 keyboard and PS/2 mouse connectors * Hard disk drive connector x1 * SATAII x2 * SPDIF OUT header x1 * IR header * USB2.0 port x 2 and headers x4 * RJ45 LAN connector x1 * Audio connectorx1 (Line-in, Line-out, MIC) * COM connector x 4

	<ul style="list-style-type: none">* LVDS Connector x1* VGA Connector x1* DVP Connector x1
--	---

1-3 Layout Diagram & Jumper Setting

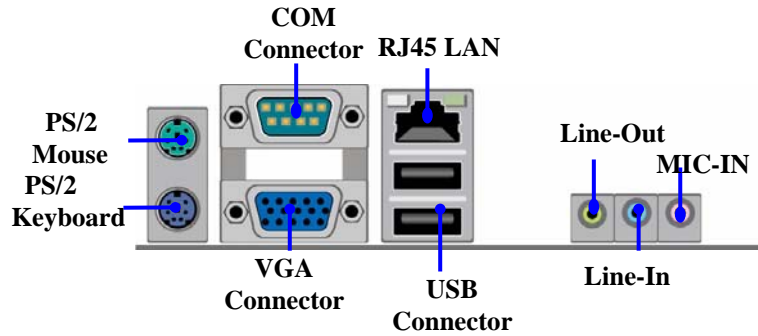

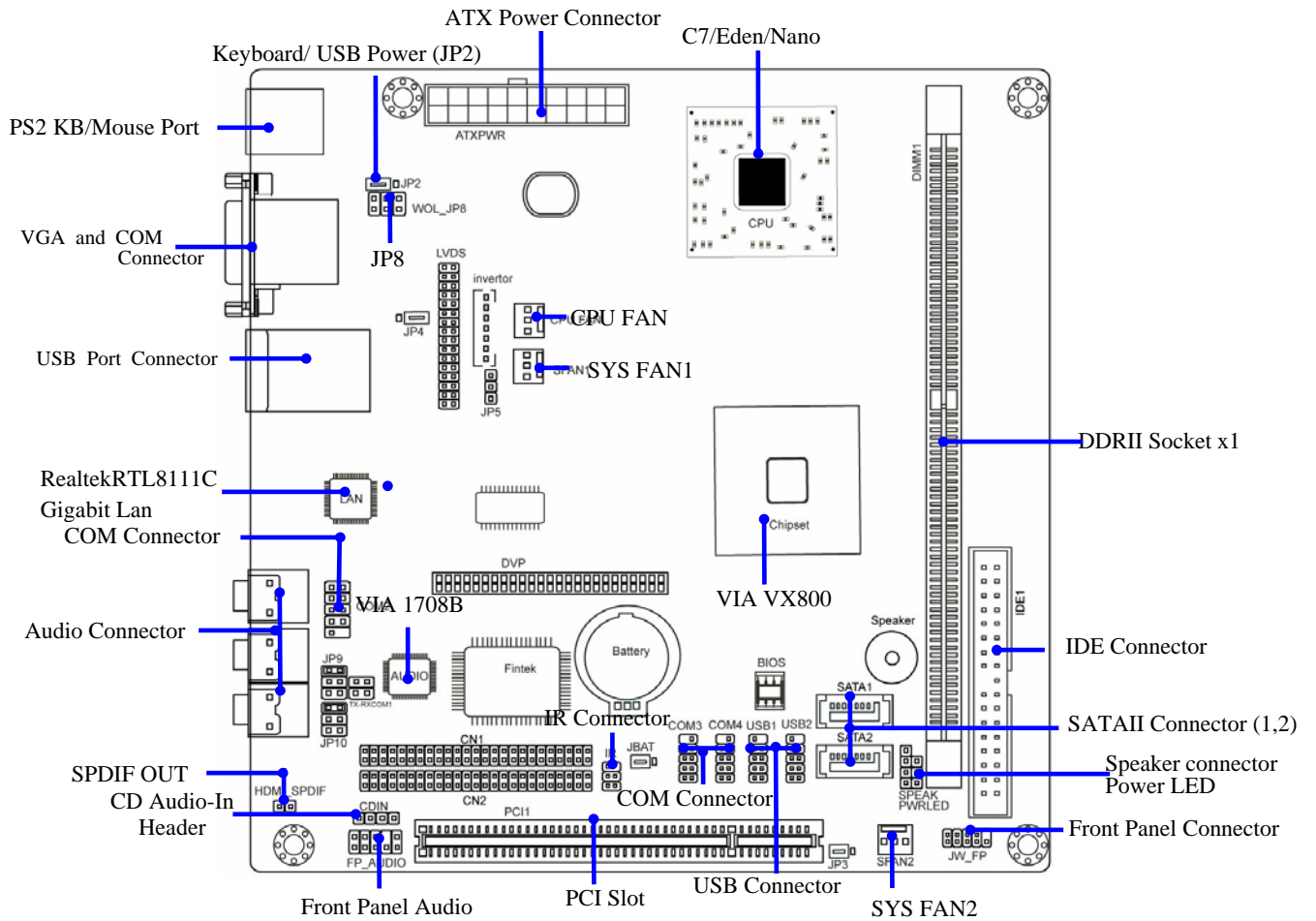

Jumper

Jumper	Name	Description	Page
JP2	KB/USB Power On Function Setting	3-pin Block	P.7
JBAT	CMOS RAM Clear Function Setting	3-pin Block	P.7
JP3	USB Power On Function Setting	3-pin Block	P.8
JP4	LVDS5V/3.3V Select	3-pin Block	P.8
JP8	Power RS232 Function Select	6-pin Block	P.9
JP5	LVDS Inverter Power On Setting	3-pin Block	P.9
JP9	Power RS232 Function Select	6-pin Block	P.10
JP10	Power RS232/422/485 Function Select	6-pin Block	P.10

Connectors

Connector	Name	Description	Page
USB1,USB2	USB Port Connector	4-pin Connector	P.12
UL2	RJ45 LAN Connector	RJ-45 Connector	P.12
VGA	Video Graphic Attach Connector	D-sub15-pin Female	P.12
AUDIO1	Line-Out /MIC/Line-In Audio Connector	3 Phone Jack	P.12
COM1	Serial Port COM1 Connector	9-pin Connector	P.12

Headers

Header	Name	Description	Page
SYSFAN1, SYSFAN2	FAN Speed Headers	3-pin Block	P.19
AUDIO2	Front panel audio Headers	9-pin block	P.13
IR	IR infrared module Headers	5-pin Block	P.18
CDIN	CD Audio-In Header	4-pin Block	P.13
PWR LED	Power LED	4-pin Block	P.18
LVDS	LVDS Connector	32-pin Block	P.14
Inverter	LVDS Inverter Connector	7-pin Block	P.15
COM2,3,4	Serial Port COM1 Connector	9-pin Connector	p.20
JW_FP (PWR LED/ HD LED/ /Power Button /Reset)	Front Panel Header (PWR LED/ HD LED/ /Power Button /Reset)	9-pin Block	P.19
ATXPWR	ATX Power Connector	24-pin Block	p.10
SATA1~2	Serial ATAII IDE Connector	7-pin Connector	p.12
TX-RXCOM1	RS422/485 Header	4-pin Block	p.11

Chapter 2

2-1 Jumper Setting

(1) JP2: KB/USB Power On Function Setting

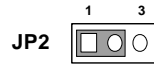
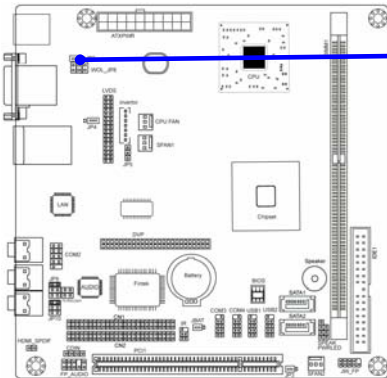

1-2 K.B&USB POWER-ON Disacted

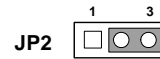

2-3 K.B& USB POWER-ON Enabled

(2) Clear CMOS (3-pin): JBAT

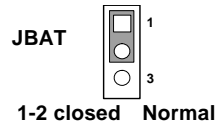
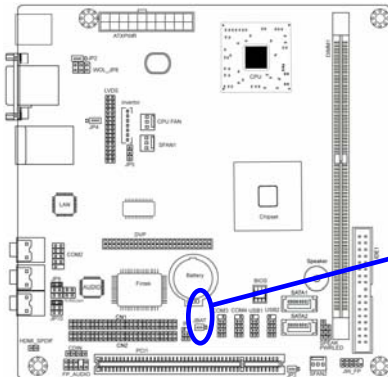

1-2 closed Normal

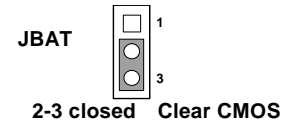

2-3 closed Clear CMOS

CMOS RAM Clear Setting

(3) JP3: USB Power On Function Setting (3-pin)

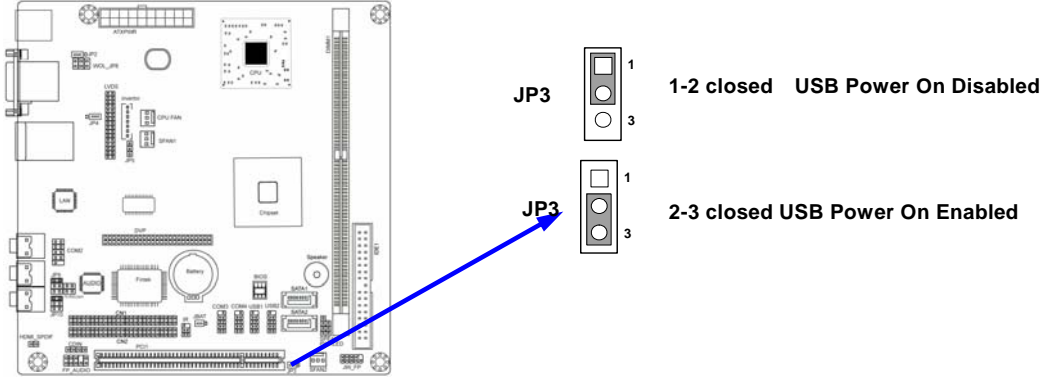

(4) JP4: LVDS 5V/3.3V Function setting (3-pin)

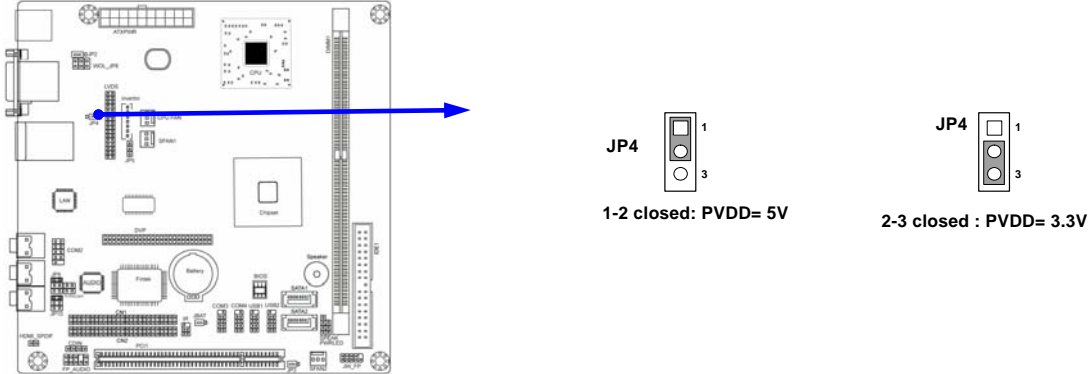

(5) JP5: Panel backlight power on/off (3-pin)

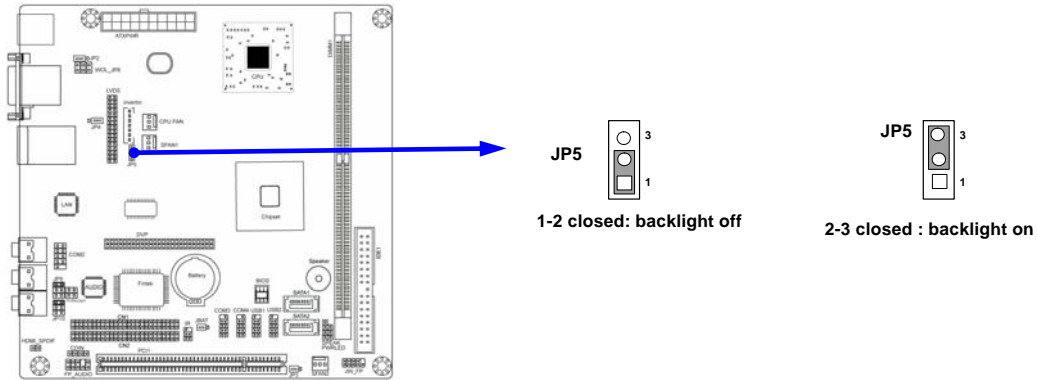

(6) JP8: COM1 Pin 9 select

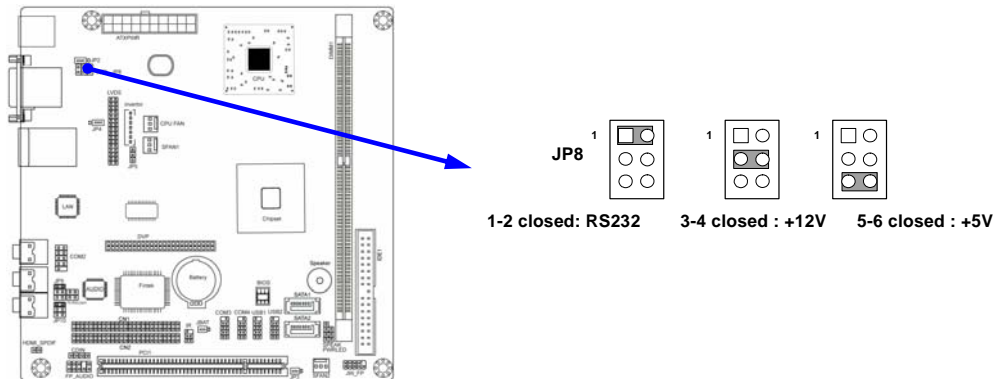

(7) JP9:COM2 Pin9 select

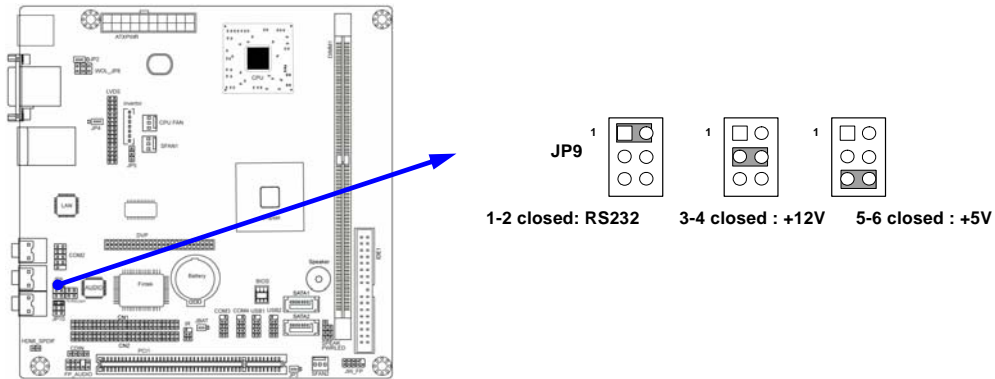

(8) JP10: RS232/422/485 Function Select

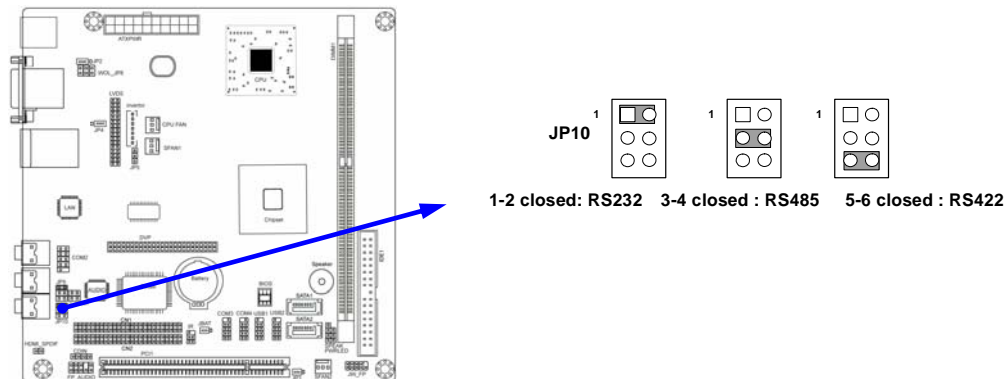

(9) TX-RXCOM1: RS422/485 header

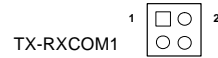
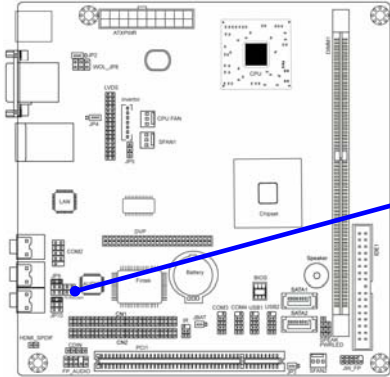

RS422/485 header

Pin definition when RS422 selected

Pin No.	Pin Definition	Pin No.	Pin Definition
1	TXDP	2	TXDN
3	RXDP	4	RXDN

Pin definition when RS485 selected

Pin No.	Pin Definition	Pin No.	Pin Definition
1	DATAP	2	DATAN

2-2 Connectors and Headers

2-2-1 Connectors

(1) Audio Connector: (Line-IN/ Line-Out/ MIC-IN)

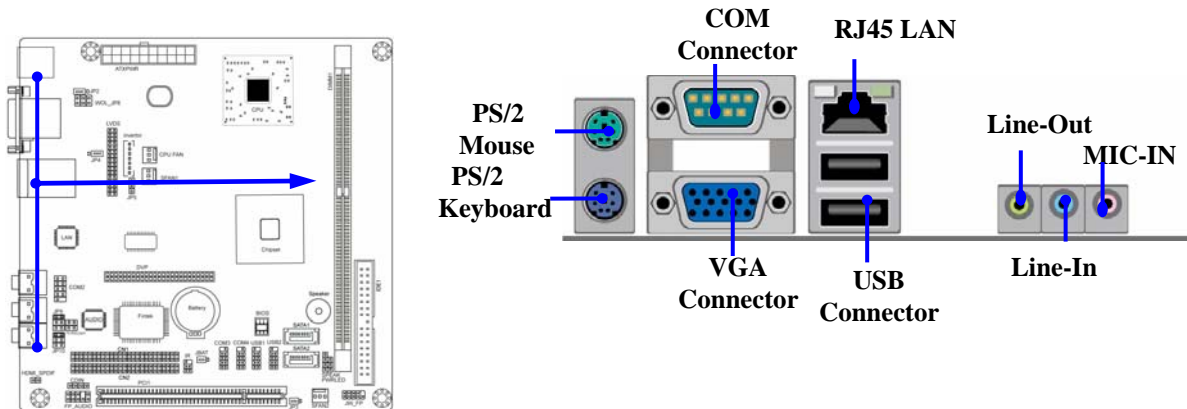

(2) Serial-ATA Port connector: SATA1/SATA2

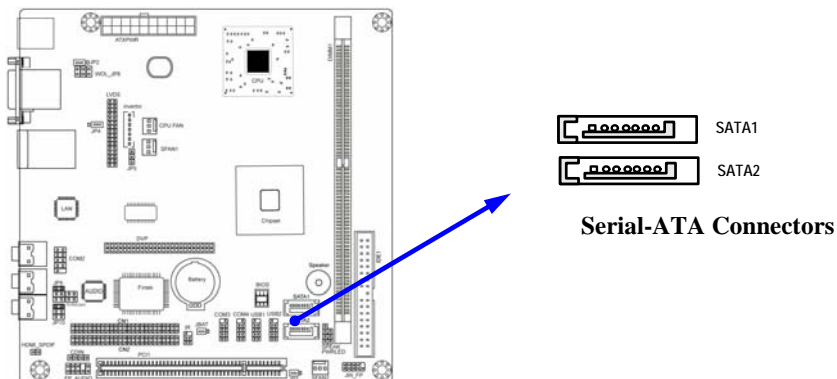

2-2-2 Headers

(1) Front panel audio (9-pin): AUDIO2

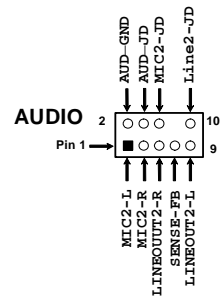
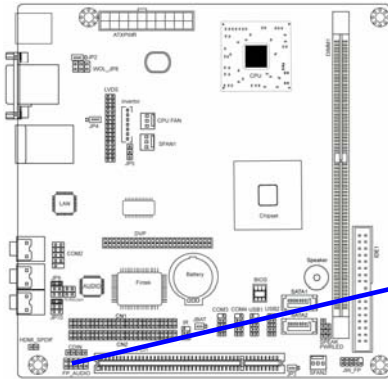

Line-Out, MIC Headers

(2) CD AUDIO-In Headers (4-pin): CDIN

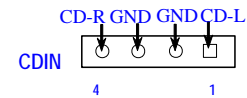
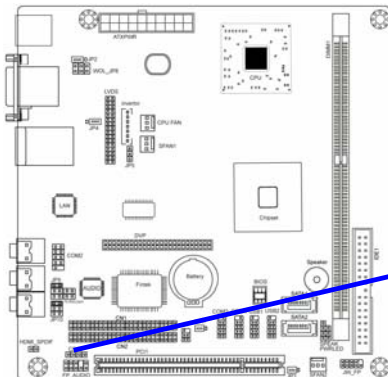

CD Audio-In Headers

(3) LVDS Headers: LVDS

Pin NO.	Pin Define	Pin NO.	Pin Define
Pin 1	-LCD7	Pin 2	LCD7
Pin 3	-LCLK2	Pin 4	LCLK2
Pin 5	-LCD6	Pin 6	LCD6
Pin 7	-LCD5	Pin 8	LCD5
Pin 9	-LCD4	Pin 10	LCD4
Pin 11	GND	Pin 12	GND
Pin 13	GND	Pin 14	GND
Pin 15	GND	Pin 16	GND
Pin 17	LCD3	Pin 18	-LCD3
Pin 19	LCLK1	Pin 20	-LCLK1
Pin 21	LCD2	Pin 22	-LCD2
Pin 23	LCD1	Pin 24	-LCD1
Pin 25	LCD0	Pin 26	-LCD0
Pin 27	PVDD	Pin 28	PVDD
Pin 29	PVDD	Pin 30	PVDD
Pin 31	GND	Pin 32	GND

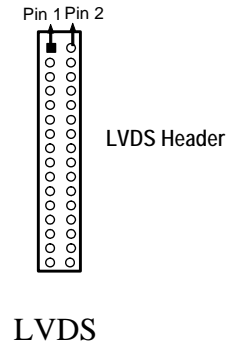
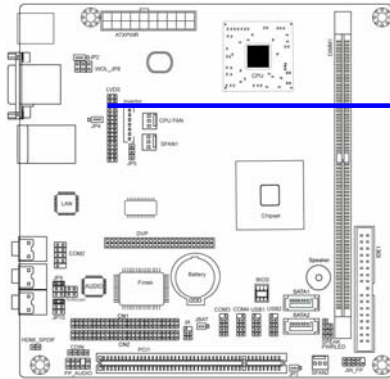

(4) Pin-headers of LVDS Inverter:

Pin 1 and pin2: VCC of inverter

Pin3、pin4 and pin6: GND

Pin5: Backlight

Pin7: Brightness

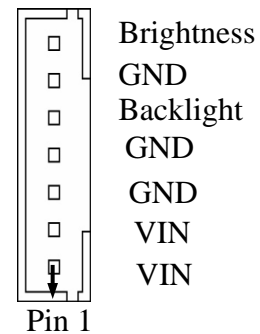
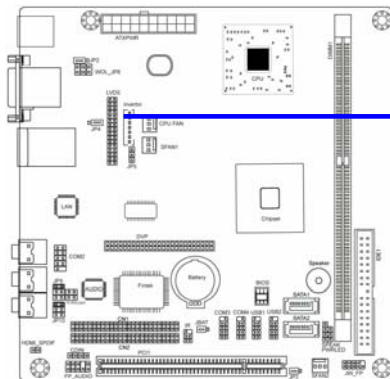

(5) JWDB Header:

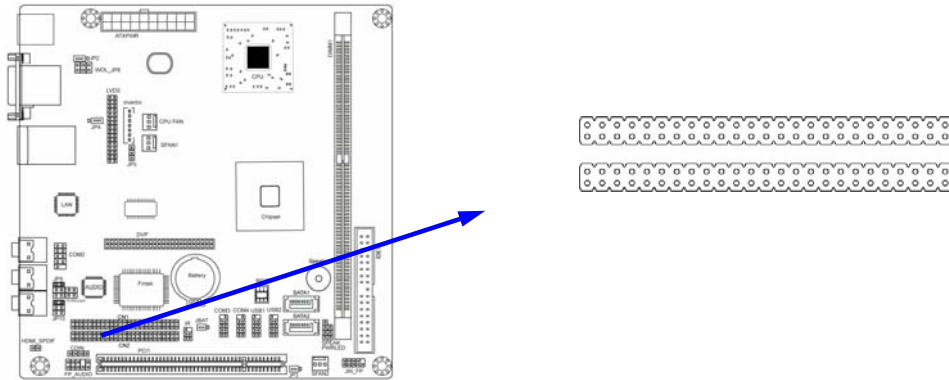

CN1

Pin NO.	Pin Define	Pin NO.	Pin Define
Pin 1	GND	Pin 2	GND
Pin 3	PCICLK2	Pin 4	-IRDY
Pin 5	-INTR_A	Pin 6	+3.3V
Pin 7	-INTR_D	Pin 8	-DEVSEL
Pin 9	-12V	Pin 10	-PERR
Pin 11	LPC_24_48M	Pin 12	-PERR
Pin 13	PCICLK3	Pin 14	+3.3v
Pin 15	PCICLK1	Pin 16	-SERR
Pin 17	GND	Pin 18	+3.3v
Pin 19	-REQ1	Pin 20	C_-BE1
Pin 21	-REQ2	Pin 22	A_D14
Pin 23	A_D31	Pin 24	GND
Pin 25	A_D29	Pin 26	A_D12
Pin 27	GND	Pin 28	A_D10
Pin 29	A_D27	Pin 30	GND

Pin 31	A_D25	Pin 32	A_D8
Pin 33	+3.3V	Pin 34	A_D7
Pin 35	C_-BE3	Pin 36	+3.3V
Pin 37	A_D23	Pin 38	A_D5
Pin 39	GND	Pin 40	A_D3
Pin 41	A_D21	Pin 42	GND
Pin 43	A_D19	Pin 44	A_D1
Pin 45	LAD3	Pin 46	LAD0
Pin 47	A_D17	Pin 48	LAD1
Pin 49	C_-BE2	Pin 50	LAD2

CN2

Pin NO.	Pin Define	Pin NO.	Pin Define
Pin 1	12V	Pin 2	-FRAME
Pin 3	+5V	Pin 4	GND
Pin 5	-INTR_C	Pin 6	-TRDY
Pin 7	-REQ3	Pin 8	GND
Pin 9	-GNT3	Pin 10	-STOP
Pin 11	+3.3VSUS	Pin 12	+3.3V
Pin 13	-PCIRSTX	Pin 14	GND
Pin 15	-GNT2	Pin 16	PAR
Pin 17	-GNT1	Pin 18	A_D15
Pin 19	GND	Pin 20	+3.3V
Pin 21	-PME	Pin 22	A_D13
Pin 23	A_D30	Pin 24	A_D11
Pin 25	+3.3V	Pin 26	GND
Pin 27	A_D28	Pin 28	A_D6

Pin 29	A_D26	Pin 30	C_-BE0
Pin 31	GND	Pin 32	+3.3V
Pin 33	A_D24	Pin 34	A_D6
Pin 35	A_D20	Pin 36	A_D4
Pin 37	+3.3V	Pin 38	GND
Pin 39	A_D22	Pin 40	A_D2
Pin 41	+3.3VSUS	Pin 42	A_D0
Pin 43	GND	Pin 44	-LDRQ
Pin 45	A_D18	Pin 46	-LFRAME
Pin 47	A_D16	Pin 48	+5V
Pin 49	+3.3V	Pin 50	GPIO1

(6) IR infrared module Headers (5-pin): IR

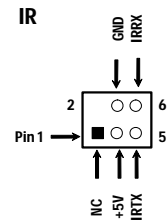
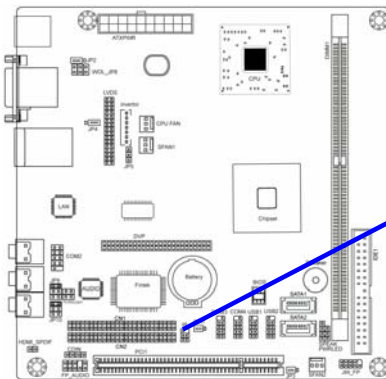

IR infrared module Header

(7) JW-FP (9-pin)

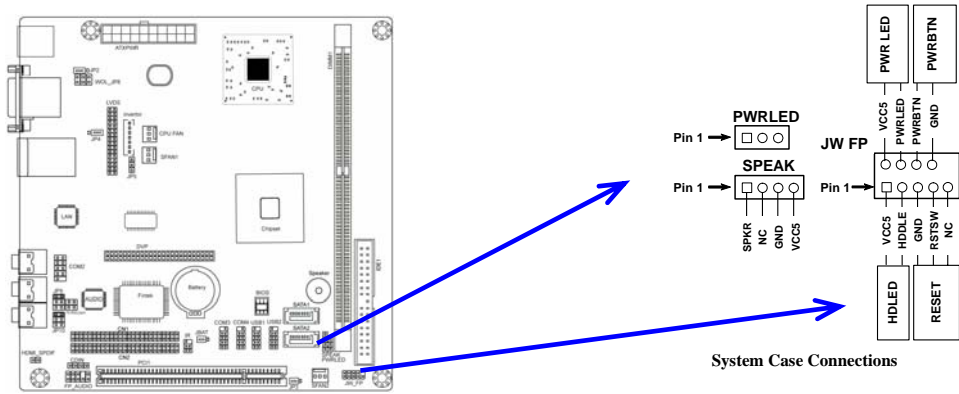

(8) FAN Speed Headers (3-pin): CPUFAN, SFAN1/SFAN2

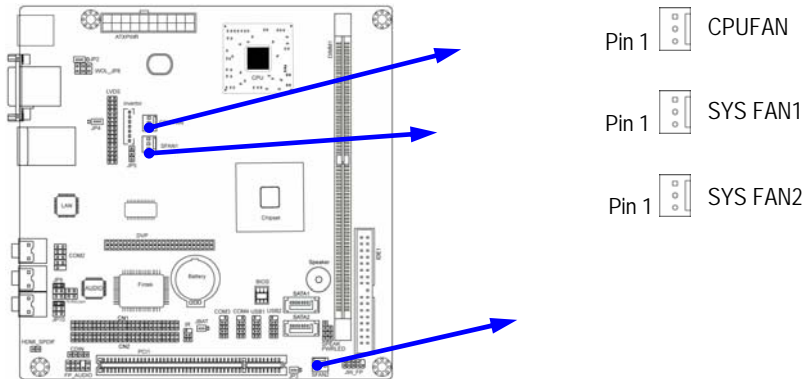

(9) COM Connectors (9-pin):

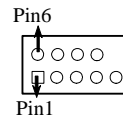
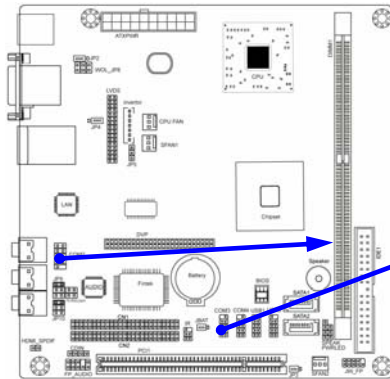

Serial COM Port 9-pin Block

Pin No.	Pin Definition	Pin No.	Pin Definition
Pin 1	DCD	Pin 6	DSR
Pin 2	RXD	Pin 7	RTS
Pin 3	TXD	Pin 8	CTS
Pin 4	DTR	Pin 9	RI
Pin 5	GND		

Chapter 3

Introducing BIOS

Attention: The BIOS options shown in this manual is for reference use only. We reserve the right to update the BIOS version without advance notice.

The BIOS is a program located on a Flash Memory on the motherboard. This program is a bridge between motherboard and operating system. When you start the computer, the BIOS program will gain control. The BIOS first operates an auto-diagnostic test called POST (power on self test) for all the necessary hardware, it detects the entire hardware device and configures the parameters of the hardware synchronization. Only when these tasks are completed done it gives up control of the computer to operating system (OS). Since the BIOS is the only channel for hardware and software to communicate, it is the key factor for system stability, and in ensuring that your system performance as its best.

In the BIOS Setup main menu of Figure 3-1, you can see several options. We will explain these options step by step in the following pages of this chapter, but let us first see a short description of the function keys you may use here:

- Press <Esc> to quit the BIOS Setup.
- Press ↑↓←→ (up, down, left, right) to choose, in the main menu, the option you want to confirm or to modify.
- Press <F10> when you have completed the setup of BIOS parameters to save these parameters and to exit the BIOS Setup menu.
- Press Page Up/Page Down or +/- keys when you want to modify the BIOS parameters for the active option.

3-1 Entering Setup

Power on the computer and by pressing immediately allows you to enter Setup.

If the message disappears before you respond and you still wish to enter Setup, restart the system to try again by turning it OFF then ON or pressing the “RESET” button on the system case. You may also restart by simultaneously pressing <Ctrl>, <Alt> and <Delete> keys. If you do not press the keys at the correct time and the system does not boot, an error message will be displayed and you will again be asked to

Press <F1> to continue, or to enter Setup

3-2 Getting Help

Main Menu

The on-line description of the highlighted setup function is displayed at the bottom of the screen.

Status Page Setup Menu/Option Page Setup Menu

Press F1 to pop up a small help window that describes the appropriate keys to use and the possible selections for the highlighted item. To exit the Help Window, press <Esc>.

3-3 The Main Menu

Once you enter Award® BIOS CMOS Setup Utility, the Main Menu (Figure 3-1) will appear on the screen. The Main Menu allows you to select from fourteen setup functions and two exit choices. Use arrow keys to select among the items and press <Enter> to accept or enter the sub-menu.

Phoenix - AwardBIOS CMOS Setup Utility

Standard CMOS Features	Miscellaneous Control
Advanced BIOS Features	Load Optimized Defaults
Advanced Chipset Features	Load standard Defaults
Integrated Peripherals	Set Supervisor Password
Power Management Setup	Set User Password
PnP/PCI Configurations	Save & Exit Setup
PC Health Status	Exit Without Saving
Esc : Quit F9 : Menu in BIOS ↑↓→← : Select Item	
F10 : Save & Exit Setup	

Figure 3-1

Standard CMOS Features

Use this Menu for basic system configurations.

Advanced BIOS Features

Use this menu to set the Advanced Features available on your system.

Advanced Chipset Features

Use this menu to change the values in the chipset registers and optimize your system's performance.

Integrated Peripherals

Use this menu to specify your settings for integrated peripherals.

Power Management Setup

Use this menu to specify your settings for power management.

Miscellaneous Control

Use this menu to specify your settings for **Miscellaneous Control**.

PC Health Status

This entry shows your PC health status.

Power User Overclock Settings

Use this menu to specify your settings (frequency, Voltage) for overclocking demand

CPU Thermal Throttling Setting

The selection is set for activating the active CPU Thermal Protection by flexible CPU loading adjustment in the arrange of temperature you defined.

Load Optimized Defaults

Use this menu to load the BIOS default values these are setting for optimal performances system operations for performance use.

Password Settings

This entry for setting Supervisor password and User password

Save & Exit Setup

Save CMOS value changes to CMOS and exit setup.

Exit Without Saving

Abandon all CMOS value changes and exit setup.

3-4 Advanced BIOS Features

Phoenix - AwardBIOS CMOS Setup Utility

Advanced BIOS Features

		Item Help
CPU Feature	Press Enter	
Hard Disk Boot Priority	Press Enter	
Virus Warning	Disabled	
CPU L1&L2 Cache	Enabled	Menu Level >
CPU L2 Cache ECC Checking	Enabled	
Quick power on self Test	Enabled	
First Boot Device	HARD DISK	
Second Boot Device	CDROM	
Third Boot Device	LS120	
Boot other Device	Enabled	
Boot Up NumLock Status	On	
Typematic Rate Setting	Disabled	
Typematic Rate (Chars/Sec)	6	
Typematic Delay (Msec)	250	
Security Option	Setup	
APIC Mode	Enabled	
MPS Version Control For OS	1.4	
OS Select For DRAM > 64MB	Non-OS2	
HDD S.M.A.R.T. Capability	Disabled	
Video BIOS Shadow	Enabled	

↑↓→← Move Enter:Select +/-/PU/PD=Value F10:Save ESC:Exit F1:General Help
F5:Previous Values F6:Optimized Defaults F7:Standard Defaults

Hard Disk Boot Priority

The selection is for you to choose the hard disk drives priorities to boot from.

Virus Warning

The selection Allow you to choose the VIRUS Warning feature for IDE Hard Disk boot sector protection. If this function is enabled and someone attempt to write data into this area, BIOS will show a warning message on screen and alarm beep.

Disabled (default) No warning message to appear when anything attempts to access the boot sector or hard disk partition table.

Enabled Activates automatically when the system boots up causing a warning message to appear when anything attempts to access the boot sector of hard disk partition table.

CPU Internal Cache

The default value is Enabled.

Enabled (default) Enable cache

Disabled Disable cache

Note: The internal cache is built in the processor.

External Cache

Choose Enabled or Disabled. This option enables the Level 2 cache memory.

Quick Power On Self-Test

This category speeds up Power On Self Test (POST) after you power on the computer. If this is set to Enabled, BIOS will shorten or skip some check items during POST.

Enabled (default) Enable quick POST

Disabled Normal POST

First/Second/Third Boot Device

The BIOS attempts to load the operating system from the devices in the sequence selected in these items. The settings are Floppy, LS/ZIP, HDD-0/HDD-1/HDD-3, SCSI, CDROM, LAD and Disabled.

Boot Up Floppy Seek

During POST, BIOS will determine if the floppy disk drive installed is 40 or 80 tracks. 360K type is 40 tracks while 760K; 1.2M and 1.44M are all 80 tracks.

Boot Up NumLock Status

The default value is on.

On (default) Keypad is numeric keys.

Off Keypad is arrow keys.

Gate A20 Option

Normal The A20 signal is controlled by keyboard controller or chipset hardware.

Fast (default) The A20 signal is controlled by port 92 or chipset specific method.

Typematic Rate Setting

Keystrokes repeat at a rate determined by the keyboard controller. When enabled, the typematic rate and typematic delay can be selected. The settings are: Enabled/Disabled.

Typematic Rate (Chars/Sec)

Set the number of times a second to repeat a keystroke when you hold the key down. The settings are: 6, 8, 10, 12, 15, 20, 24, and 30.

Typematic Delay (Msec)

Sets the delay time after the key is held down before beginning to repeat the keystroke. The settings are 250, 500, 750, and 1000.

Security Option

This category allows you to limit access to the system and Setup, or just to Setup.

System The system will not boot and access to Setup will be denied if the correct password is not entered at the prompt.

Setup (default) The system will boot, but access to Setup will be denied if the correct password is not entered prompt.

HDD S.M.A.R.T Capability

This option allow you to enable the HDD S.M.A.R.T Capability (Self-Monitoring, Analysis and Reporting Technology) . You can choose from Enabled and Disabled.

MPS Version Control For OS 1.4

This option is only valid for multiprocessor motherboards as it specifies the version of the Multiprocessor Specification (MPS) that the motherboard will use.

OS Select For DRAM > 64MB

Allows OS2[®] to be used with >64MB or DRAM. Settings are Non-OS/2 (default) and OS2. Set to OS/2 if using more than 64MB and running OS/2[®].

Video BIOS shadow

Enabled copies video BIOS to shadow RAM Improves performance.

3-4-1 CPU Feture

Phoenix - AwardBIOS CMOS Setup Utility

CPU Features

Thermal Management	Thermal Monitor 2	Item Help
Thermal Monitor Bus Ratio	8x	Menu Level >
Thermal Monitor Bus VID	0.700v	
↑↓→← Move Enter:Select +/-/PU/PD:Value F10:Save ESC:Exit F1:General Help F5:Previous Values F6:Optimized Defaults F7:Standard Defaults		

Thermal Management

Thermal monitor 1 (on die throttling)

Thermal monitor 2 (Ratio&VID transition)

Thermal monitor 3 (Dynamic Ratio&VID transition)

Thermal Monitor Bus Ratio

Represent the frequency (bus ratio) of the throttled performance state that will be invited when the on-diesensor goes from not hot to hot.

Thermal Monitor Bus VID

Represent the voltage of the throttled performance state that will be invited when the on diesensor goes from not hot to hot.

3-5 Intergrated peripherals

Phoenix - AwardBIOS CMOS Setup Utility Intergrated peripheral

Onboard IDE Function	Press Enter	Item Help
Onboard Device Function	Press Enter	
Onboard Superio Function	Press Enter	Menu Level >>
USB Device Setting	Press Enter	
Init Display First	PCI Slot	
↑↓→← Move Enter:Select +/-/PU/PD:Value F10:Save ESC:Exit F1:General Help F5:Previous Values F6:Optimized Defaults F7:Standard Defaults		

Phoenix - AwardBIOS CMOS Setup Utility Onboard Device Function

Onboard HD Audio Deivice	Auto	Item Help
Realtek Lan1 Device	Enabled	
Realtek Lan1 Bootrom	Disabled	Menu Level >>
↑↓→← Move Enter:Select +/-/PU/PD:Value F10:Save ESC:Exit F1:General Help F5:Previous Values F6:Optimized Defaults F7:Standard Defaults		

Onboard HD Audio

This item allows you to decide to enable/disable the chipset family to support HD Audio. The settings are: Enabled, Disabled.

Onboard PCIE LAN Bootrom

Decide whether to invoke the boot ROM of the onboard LAN chip.

3-6 PC Health Status

This section shows the Status of you CPU, Fan, and Warning for overall system status. This is only available if there is Hardware Monitor onboard.

Phoenix - AwardBIOS CMOS Setup Utility

PC Health Status

Shutdown Temperature	Disabled	Item Help
Show PC Health In Post	Enabled	
CPU Thermal-Throttling	Disabled	Menu Level >
CPU Thermal-Throttling Temp	70c	
CPU Thermal-Throttling Duty	50%	
CPU Thermal-Throttling Beep	Enabled	
Smart fan configurations	Press Enter	
Vcore	0.97V	
+1.5v	1.49V	
+5v	5.02v	
+12v	11.98v	
+5VSB	5.06V	
VDIMM	1.84V	
VCC3	3.42V	
3.3 SUS	3.34V	
VBAT	3.22V	
CPU Temperature	54c/129F	
SYS Temperature	33c/93F	
CPU FAN Speed	0RPM	
SYS FAN1 Speed	0RPM	
SYS FAN2 Speed	0RPM	
↑↓→← Move Enter:Select +/-/PU/PD:Value F10:Save ESC:Exit F1:General Help F5:Previous Values F6:Optimized Defaults F7:Standard Defaults		

Show PC Health in Post

During Enabled, it displays information list below. The choice is either Enabled or Disabled

CPU Smart FAN Configurations

CPU Full-Speed Temp

This item allows you setting the FAN works in full speed when the temperature over the value

which out set. If the temperature below the value but over the Idle Temperature, the FAN will works over 60% of full speed, and the higher temperature will gain higher FAN speed, after over the temperature which this item setting, the FAN works in full speed.

CPU Idle Temp

This item allows you setting the FAN works in 60% of full speed, when the temperature lower than the temperature which you setting.

Current CPU Temperature/Current System Temp/Current FAN1, FAN2 Speed/Vcore/Vdd/3.3V/+5V/+12V/-12V/VBAT(V)/5VSB(V)

This will show the CPU/FAN/System voltage chart and FAN Speed.

3-7 Advanced Chipset Features

The Advanced Chipset Features Setup option is used to change the values of the chipset registers. These registers control most of the system options in the computer.

Phoenix - AwardBIOS CMOS Setup Utility

Advanced Chipset Features

DRAM Timing Settings	Press Enter	Item Help
VGA Timing Settings	Press Enter	
PCI Timing Settings	Press Enter	
Memory Hole	Disabled	Menu Level >
System BIOS Cacheable	Enabled	
VIDEO RAM Cacheable	Disabled	
↑↓→← Move Enter: Select +/-/PU/PD: Value F10:Save ESC: Exit F1:General Help F5:Previous Values F6:Optimized Defaults F7:Standard Defaults		

System BIOS Cacheable

Selecting Enabled allows caching of the system BIOS ROM at F0000h-FFFFFFh, resulting in better system performance. However, if any program writes to this memory area, a system error may result. The settings are: Enabled and Disabled.

3-8 Power Management Setup

The Power Management Setup allows you to configure your system to most effectively save energy saving while operating in a manner consistent with your own style of computer use.

Phoenix - AwardBIOS CMOS Setup Utility

Power Management Setup

ACPI Suspend Type	S1(POS)	Item Help
Assign IRQ For ACPI	IRQ 9	
Video off option	Suspend-off	Menu Level >
Video off Method	V/H SYNC+Blank	
MODEM USE IRQ	3	
Power Button Function	Instant off	
Power after power Function	Always OFF	
HPET Support	Enabled	
WDRT Support	Disabled	
WDRT Run/stop	Stop	
WDRT Count	1023	
Wake UP Events	Press Enter	
↑↓←→ Move Enter:Select +/-/PU/PD:Value F10:Save ESC:Exit F1:General Help F5:Previous Values F6:Optimized Defaults F7:Standard Defaults		

ACPI Function

This item allows you to Enabled/Disabled the Advanced Configuration and Power Management (ACPI). The settings are Enabled and Disabled.

Video Off Method

This determines the manner in which the monitor is blanked.

DPMS (default) Initial display power management signaling.

Blank Screen This option only writes blanks to the video buffer.

V/H SYNC+Blank This selection will cause the system to turn off the vertical and horizontal synchronization ports and write blanks to the video buffer.

MODEM Use IRQ

If you want an incoming call on a modem to automatically resume the system from a power-saving mode, use this item to specify the interrupt request line (IRQ) that is used by

the modem. You might have to connect the fax/modem to the motherboard Wake On Modem connector for this feature to work.

Soft-Off by PWRBTN

Under ACPI (Advanced Configuration and Power management Interface) you can create a software power down. In a software power down, the system can be resumed by Wake up Alarms. This item lets you install a software power down that is controlled by the power Button on your system. If the item is set to Instant-Off, then the power button causes a software power down. If the item is set to Delay 4 Sec, then you have to hold the power button down for four seconds to cause a software power down.

3-9 PnP/PCI Configuration

Phoenix - AwardBIOS CMOS Setup Utility

Pnp/PCI Configuration

IRQ Resources	Press Enter	Item Help
PCI/VGA Palette Snoop	Disabled	
Assign IRQ For VGA	Enabled	
Assign IRQ For USB	Enabled	Menu Level >
↑↓←→ Move Enter:Select +/-/PU/PD:Value F10:Save ESC:Exit F1:General Help F5:Previous Values F6:Optimized Defaults F7:Standard Defaults		

3-10 Miscellaneous Configuration

Phoenix - AwardBIOS CMOS Setup Utility

Miscellaneous Control

Spread Spectrum	Disabled	Item Help
Current Host Frequency is	200MHz	
CPU Clock at Next boot is	200MHz	Menu Level >
Current DRAM Frequency is	333MHz	
DRAM Clock at Next Boot is	SPD	
CPU Clock Ratio is	8x	
Vcore voltage	Default	
VCC1.05 Voltage	Auto	
VCC 1.5 Voltage	1.50v(Default)	
VDIMM Voltage	1.84v(Default)	
↑↓→← Move Enter:Select +/-/PU/PD:Value F10:Save ESC:Exit F1:General Help F5:Previous Values F6:Optimized Defaults F7:Standard Defaults		

Phoenix - AwardBIOS CMOS Setup Utility

Miscellaneous Control

Auto Detect PCI CLK	Enabled	Item Help
Spread Spectrum	Disabled	
Current Host Frequency is	100MHz	Menu Level >
CPU Clock at Next boot is	100MHz	
Current DRAM Frequency is	333MHz	VCC 1.5 Voltage
DRAM Clock at Next Boot is	SPD	
CPU Clock Ratio is	8x	1.00v []
Vcore voltage	Default	1.02v []
VCC1.05 Voltage	1.05v(Default)	1.05v []
VCC 1.5 Voltage	1.50v(Default)
VDIMM Voltage	1.84v(Default)	1.25v []
		↑↓:Move ENTER:Accept ESC:Abort
↑↓→← Move Enter:Select +/-/PU/PD:Value F10:Save ESC:Exit F1:General Help F5:Previous Values F6:Optimized Defaults F7:Standard Defaults		

Phoenix - AwardBIOS CMOS Setup Utility

Miscellaneous Control

Auto Detect PCI CLK Enabled Spread Spectrum Disabled Current Host Frequency is 100MHz CPU Clock at Next boot is 100MHz Current DRAM Frequency is 333MHz DRAM Clock at Next Boot is SPD CPU Clock Ratio is 8x Vcore voltage Default VCC1.05 Voltage 1.05v(Default) VCC 1.5 Voltage 1.50v(Default) VDIMM Voltage 1.84v(Default)	Item Help Menu Level >
Vcore Voltage	
-7.5% [] -5.0% [] -2.5% [] Default +2.5% [] +30.5% []	
↑↓:Move ENTER:Accept ESC:Abort	
↑↓→← Move Enter:Select +/-/PU/PD:Value F10:Save ESC:Exit F1:General Help F5:Previous Values F6:Optimized Defaults F7:Standard Defaults	

CPU Vcore

This item allows you select the CPU Vcore Voltage xx% more than the standard value, by this function for the precise over-clocking for extra demanding of performance.

VDIMM Voltage

This item allows you select the voltage of the memory.