

InnoDisk USB EDC

USB Embedded Disk Card

Datasheet

Rev 1.1

Table of contents

| | |
|---|----|
| REVISION HISTORY..... | 3 |
| LIST OF TABLES..... | 4 |
| LIST OF FIGURES..... | 5 |
| 1. INTRODUCTION | 6 |
| 2. FEATURES | 6 |
| 3. PIN ASSIGNMENT | 7 |
| 4. SPECIFICATIONS | 7 |
| 4.1 CE AND FCC COMPATIBILITY | 7 |
| 4.2 RoHS COMPLIANCE | 7 |
| 5. ENVIRONMENTAL SPECIFICATIONS..... | 7 |
| 5.1 TEMPERATURE RANGES..... | 7 |
| 5.2 HUMIDITY | 7 |
| 5.3 SHOCK AND VIBRATION..... | 7 |
| 5.4 MEAN TIME BETWEEN FAILURES (MTBF) | 8 |
| 5.5 MECHANICAL DIMENSIONS..... | 8 |
| 5.6 ELECTRICAL SPECIFICATIONS | 10 |
| 5.6.1 <i>Absolute Maximum Ratings</i> | 10 |
| 5.6.2 <i>Operating Conditions</i> | 10 |
| 5.6.3 <i>DC Characteristic</i> | 10 |

REVISION HISTORY

| Revision | Description | Date |
|----------|---------------------------|------------|
| 1.1 | Modified some information | April 2007 |
| 1.0 | First Release | March 2007 |

List of Tables

| | |
|--|----|
| TABLE 1: USB EDC VERTICAL TYPE I AND HORIZONTAL TYPE PIN ASSIGNMENTS | 7 |
| TABLE 2: USB EDC VERTICAL TYPE II PIN ASSIGNMENTS..... | 7 |
| TABLE 3: SHOCK/VIBRATION TESTING FOR USB EDC | 7 |
| TABLE 4: USB EDC MTBF..... | 8 |
| TABLE 5: USB CARD ABSOLUTE MAXIMUM RATINGS | 10 |
| TABLE 6: USB CARD OPERATING CONDITIONS..... | 10 |
| TABLE 7: USB CARD DC CHARACTERISTIC | 10 |

List of Figures

| | |
|--|---|
| FIGURE 1: MECHANICAL DIMENSION OF USB EDC VERTICAL TYPE I | 8 |
| FIGURE 2: MECHANICAL DIMENSION OF USB EDC VERTICAL TYPE II | 9 |
| FIGURE 3: MECHANICAL DIMENSION OF USB EDC HORIZONTAL TYPE (2.54MM) | 9 |
| FIGURE 4: MECHANICAL DIMENSION OF USB EDC HORIZONTAL TYPE (2.00MM) | 9 |

1. Introduction

The InnoDisk USB EDC (Embedded Disk Card) products provide high capacity USB flash memory storage that electrically complies with High-speed USB 2.0 interface & backward compatible with USB 1.1. With vertical and horizontal version for option, the device features attractive small form factor and the connectivity over USB2.0 and the NAND flash architecture provide a faster data transmission.

2. Features

The USB EDC products provide the following system features:

- Capacities:
 - Horizontal version: 256MB, 512MB, 1GB, 2GB, 4GB and 8GB
 - Vertical version: 256MB, 512MB, 1GB, 2GB and 4GB
- High-speed USB 2.0 interface; backward compatible with USB 1.1
- High reliability based on the internal 4bit ECC (Error Correction Code) function
- Read & Write performance: (maximum speed)
 - Horizontal version
 - ◆ 1GB, 2GB, 4GB, 8GB - Read: 32Mbytes/s, Write: 23Mbytes/s
 - ◆ 256MB, 512MB - Read: 19Mbytes/s, Write: 17Mbytes/s
 - Vertical version
 - ◆ 256MB, 512MB, 1GB, 2GB, 4GB - Read: 19Mbytes/s, Write: 17Mbytes/s
- Static Wear-leveling supported
- Two NAND flash interleave supported (Horizontal version: 1GB, 2GB, 4GB and 8GB)
- Low power consumption
 - Power supply: 5V±10%
 - Read/Write
 - ◆ Horizontal version: 120mA
 - ◆ Vertical version: 105mA
 - Suspend: less than 500µA
- Windows XP embedded, Windows CE.NET, DOS and Linux bootable (needed BIOS supporting boot from USB Mass Storage Class devices)
- USB EDC-to-USB Adapter (for option)
- Fixed/Removable mode (for option, default is Fixed mode)
- Temperature range:
 - Operating: 0°C ~ +75°C
 - Storage: -40°C ~ +85°C

3. Pin Assignment

See Table 1 and Table 2 for USB EDC pin assignments.

Table 1: USB EDC Vertical Type I and Horizontal Type Pin Assignments

| Vertical Type I & Horizontal Type | | | |
|-----------------------------------|---------------|---------|--------|
| Pin No. | Signal | Pin No. | Signal |
| 1 | +5VDC | 2 | NC |
| 3 | USB Data(-) | 4 | NC |
| 5 | USB Data(+) | 6 | NC |
| 7 | GND | 8 | NC |
| 9 | KEY (Blocked) | 10 | NC |

Table 2: USB EDC Vertical Type II Pin Assignments

| Vertical Type I & Horizontal Type | | | |
|-----------------------------------|---------------|---------|-------------|
| Pin No. | Signal | Pin No. | Signal |
| 1 | NC | 2 | +5VDC |
| 3 | NC | 4 | USB Data(-) |
| 5 | NC | 6 | USB Data(+) |
| 7 | NC | 8 | GND |
| 9 | KEY (Blocked) | 10 | NC |

4. Specifications

4.1 CE and FCC Compatibility

The InnoDisk USB EDC conforms to CE requirements and FCC standards

4.2 RoHS Compliance

The InnoDisk USB EDC is fully compliant with RoHS directive.

5. Environmental Specifications

5.1 Temperature Ranges

Operating Temperature Range: 0°C to +75°C

Storage Temperature Range: -40°C to +85°C

5.2 Humidity

Relative Humidity: 10-95%, non-condensing

5.3 Shock and Vibration

Table 3: Shock/Vibration Testing for USB EDC

| Reliability | Test Conditions | Reference Standards |
|---------------------------------------|---------------------------------------|---------------------|
| Vibration (Vertical version) | 7 Hz to 2 KHz, 5 g, 3 axes, 30minutes | IEC 68-2-6 |
| Mechanical Shock (Vertical version) | Duration: 10ms, 50 g, 3 axes, 15times | IEC 68-2-27 |
| Vibration (Horizontal version) | 10 Hz to 500 Hz, 5 g, 3 axes, 1hour | IEC 68-2-6 |
| Mechanical Shock (Horizontal version) | Duration: 10ms, 50 g, 3 axes, 20times | IEC 68-2-27 |

5.4 Mean Time between Failures (MTBF)

Table 2 summarizes the MTBF prediction results for various USB EDC configurations. The analysis was performed using a RAM Commander™ failure rate prediction.

- **Failure Rate:** The total number of failures within an item population, divided by the total number of life units expended by that population, during a particular measurement interval under stated condition.
- **Mean Time between Failures (MTBF):** A basic measure of reliability for repairable items: The mean number of life units during which all parts of the item perform within their specified limits, during a particular measurement interval under stated conditions.

Table 4: USB EDC MTBF

| Product | Condition | MTBF (Hours) |
|-------------------------|---------------------------|--------------|
| Vertical I & II Version | Telcordia SR-332 GB, 25°C | > 3,000,000 |
| Horizontal Version | | > 3,000,000 |

5.5 Mechanical Dimensions

Mechanical Dimension: Vertical Type I: 27.47/7.0/25.3 mm (W/T/H)

Vertical Type II: 15.2/6.4/34.1 mm (W/T/H)

Horizontal Type: (2.54mm) 37.8/26.65/8.7 mm (L/W/H)

(2.00mm) 37.8/26.65/5.0 mm (L/W/H)

Figure 1: Mechanical Dimension of USB EDC Vertical Type I

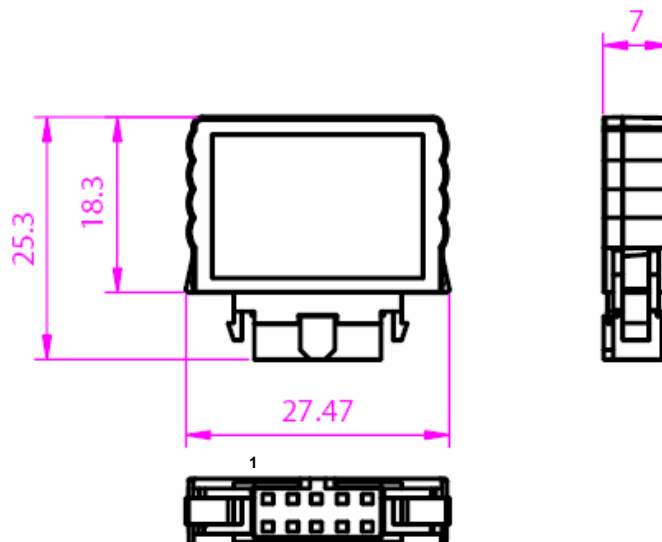

Figure 2: Mechanical Dimension of USB EDC Vertical Type II

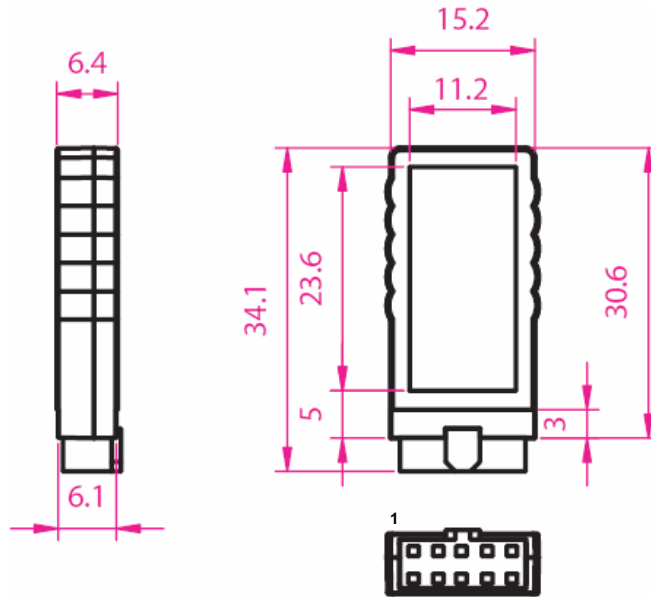

Figure 3: Mechanical Dimension of USB EDC Horizontal Type (2.54mm)

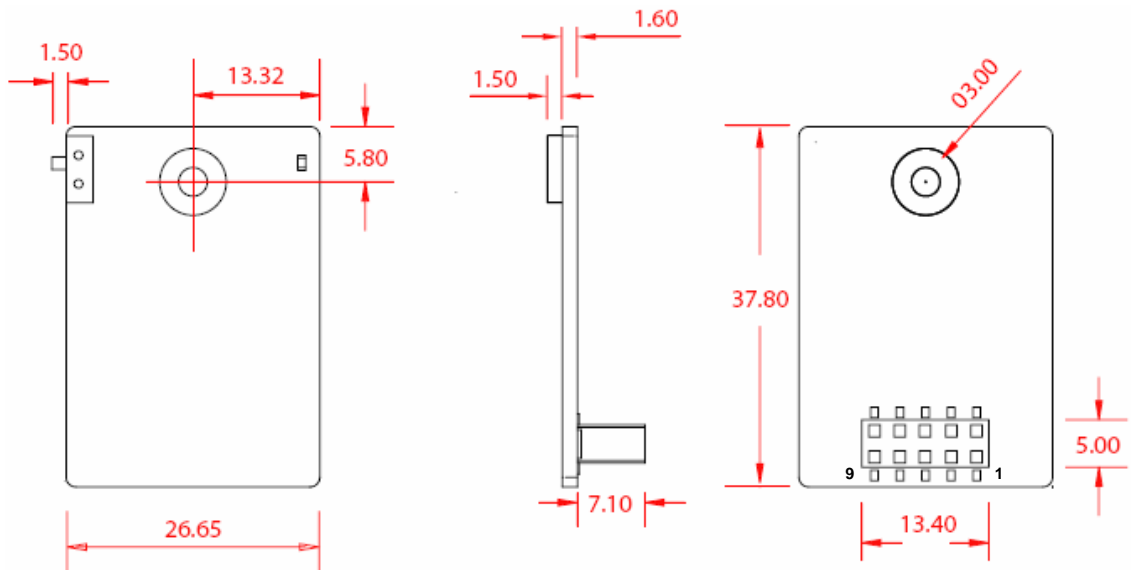
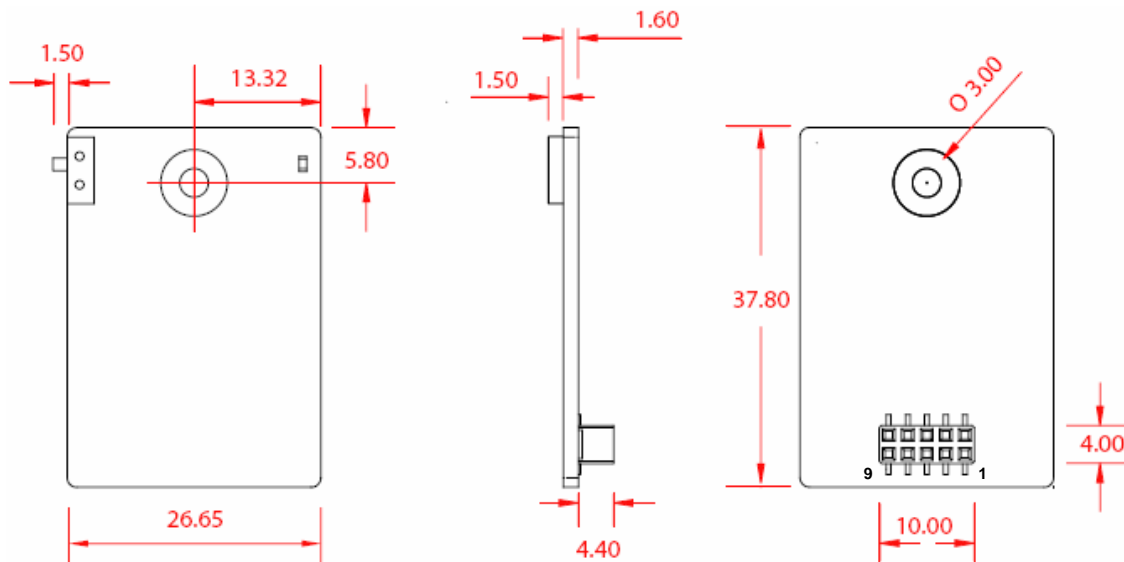

Figure 4: Mechanical Dimension of USB EDC Horizontal Type (2.00mm)



5.6 Electrical Specifications

5.6.1 Absolute Maximum Ratings

Table 5: USB EDC Absolute Maximum Ratings

| Item | Symbol | Rating | Unit |
|-------------------------------|---------------|------------|------|
| Storage Temperature | $T_{Storage}$ | -40 ~ +85 | °C |
| Ambient Operating Temperature | T_a | 0 ~ +75 | °C |
| 3.3V supply voltage | V_{CC33} | -0.3 ~ 3.6 | V |
| 1.8V supply voltage | V_{CC18} | -0.3 ~ 2 | V |
| 3.3V buffer input voltage | V_{in33} | -0.3 ~ 3.6 | V |
| 3.3V/5V buffer input voltage | V_{in335} | -0.3 ~ 5 | V |
| 1.8V buffer input voltage | V_{in18} | -0.3 ~ 2 | V |

5.6.2 Operating Conditions

Table 6: USB EDC Operating Conditions

| Item | Symbol | Rating | Unit |
|-----------------------|-------------|-----------|------|
| USB 5V supply voltage | $USBV_{in}$ | 3.2 ~ 5.5 | V |
| 3.3V supply voltage | V_{DD33} | 3.0 ~ 3.6 | V |
| 1.8V supply voltage | V_{DD18} | 1.6 ~ 2 | V |

5.6.3 DC Characteristic

Table 7: USB EDC DC Characteristic

| Item | Symbol | Min | Max | Unit |
|-----------------------|---------------|------|-----|------|
| TTL Input low voltage | V_{IL_TTL} | -0.3 | 0.8 | V |

| | | | | |
|---|---------------------|----------------|-------|----|
| TTL Output high voltage | V_{OH_TTL} | $0.9 V_{CC33}$ | | V |
| TTL Output low voltage | V_{OL_TTL} | | 0.45 | V |
| TTL Output high current | I_{OH_TTL} | -4 | | mA |
| TTL Output low current | I_{OL_TTL} | | 4 | mA |
| USB Input high voltage for low/full speed | V_{IH_USB} | 2.0 | | V |
| USB Input low voltage for low/full speed | V_{IL_USB} | | 0.8 | V |
| Difference common mode input range for low/full speed | $V_{I_USB_CM}$ | 0.8 | 2.5 | V |
| USB high speed squelch input detection threshold | $V_{I_USB_HSSQ}$ | 0.1 | 0.15 | V |
| USB high speed disconnect input detection threshold | $V_{I_USB_HSDSC}$ | 0.525 | 0.625 | V |
| USB high speed signaling common mode range | $V_{I_USB_HSCM}$ | -0.05 | 0.5 | V |
| USB output high voltage for low/full speed | V_{OH_USB} | 2.8 | 3.6 | V |
| USB output low voltage for low/full speed | V_{OL_USB} | 0 | 0.3 | V |
| USB output high voltage for high speed | $V_{OH_USB_HS}$ | 0.36 | 0.44 | V |
| USB output low voltage for high speed | $V_{OL_USB_HS}$ | -0.01 | 0.01 | V |
| USB output high current for low/full speed | I_{OH_USB} | -10 | | mA |
| USB output low current for low/full speed | I_{OL_USB} | | 10 | mA |
| USB output high current for high speed | $I_{OH_USB_HS}$ | -40 | | mA |
| USB output low current for high speed | $I_{OL_USB_HS}$ | | 40 | mA |